

Cabinet Dust Collectors

Series 50 to 80, Models 54, 64, 66, 75, 81 and 84

Compact, self-contained dust collector delivers excellent efficiency for in-plant dust and smoke control.

- Reliable and cost-efficient filtration on nuisance dust generated in industrial operations.
- High collection efficiency of 99.9% allows recirculation of heated and/or air-conditioned plant air.
- Manually-operated filter shaker makes filter cleaning easy.
- Quick access to dust drawers and dust pails provide easy and safe maintenance.
- Filter changes have never been easier with the EZ Filter Pack™, a one-piece, lightweight filter bag that installs without tools and provides a positive pressure seal.



**Series 70 with Dust Drawer
and Series 60 with 5-Gallon Pail Pack**

Excellent efficiency on nuisance dust for intermittent-duty applications.

- | | |
|-------------------------|---------------------|
| ■ Grinding | ■ Packaging |
| ■ Buffing and polishing | ■ Abrasive blasting |
| ■ Machining | ■ Dental labs |
| ■ Metalworking | ■ Textiles |

Cabinet Dust Collectors

Easy Maintenance

- Factory installed filter packs include standard cotton sateen bags, polyester medium inserts, galvanized bag clips, slide latches, and center support bar.
- One-piece construction includes a closed-cell urethane gasket to ensure a positive pressure seal.
- Four filter media selections and three construction choices provide a variety of options to customize the unit for your specific application.

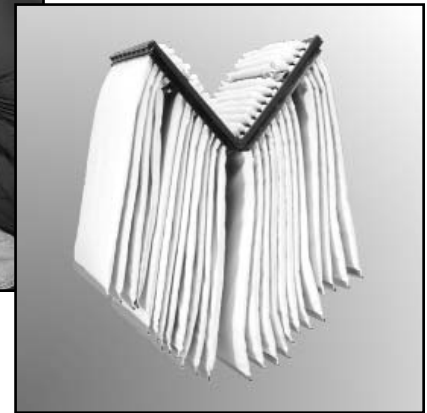

Multiple Rating Table

Model	Nominal Airflow* (cfm)	Motor (hp)	Inlet Qty/ Size	Velocity (fpm)	External Static Pressure ("wg)	Pressure Drop Clean Filter ("wg)
54	284	0.5	(1) 3"	5804	3.16	0.45
	231			4705	3.35	0.35
	171			3491	3.55	0.30
64	500	.75	(1) 4"	5720	3.50	0.80
	426			4950	3.90	0.60
	323			3790	4.50	0.45
	267		(2) 3"	5447	2.75	0.84
	232			4739	3.30	0.67
	184			3758	4.00	0.54
	307		(1) 3"	6269	3.75	0.40
	256			5222	4.00	0.35
	188			3842	4.30	0.26
66	549	0.5	(1) 3"	33.53	1.045	0.90
	263			5374	4.32	0.25
	196			4005	4.45	0.22
	136			2775	4.78	0.16
75	550	1	(1) 4"	6322	4.90	0.72
	500			5747	5.30	0.65
	450			5172	5.40	0.56
	400			4598	5.50	0.48
	325		(2) 3"	6633	4.50	0.90
	290			5918	4.90	0.80
	230			4694	5.40	0.60
	335		(1) 3"	6837	4.70	0.40
	300			6122	4.90	0.30
	200			4082	5.30	0.20
	175			3571	5.40	0.15

Model	Nominal Airflow* (cfm)	Motor (hp)	Inlet Qty/ Size	Velocity (fpm)	External Static Pressure ("wg)	Pressure Drop Clean Filter ("wg)
81	1071	1.5	(1) 6"	5462	3.70	1.15
	987			5034	4.20	1.05
	874			4460	4.70	0.90
	524			6021	3.75	1.05
	475		(2) 4"	5462	4.50	0.90
	418			4806	5.00	0.75
	599			6890	4.80	0.45
	493		(1) 4"	5664	5.00	0.30
	424			4873	5.00	0.25
84	1231	3	(1) 6"	6281	5.00	2.05
	1143			5831	5.80	1.85
	1036			5283	6.60	1.78
	875			4460	7.30	1.05
	652		(2) 4"	7493	5.90	2.20
	573			6581	6.85	1.85
	438			5034	7.90	1.05
	1155		(1) 5"	8491	7.80	1.85
	997			7330	8.90	1.75
	789			5804	8.55	0.89
	700		(1) 4"	8050	7.75	0.59
	610			6994	7.80	0.46
	505			5804	7.80	0.31

* Based on clean filters.

Cabinet Dust Collectors

Dimensions & Specifications

Cabinet Base

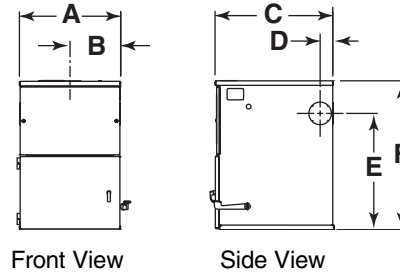

55-Gallon Drum Pack

5-Gallon Pail Pack

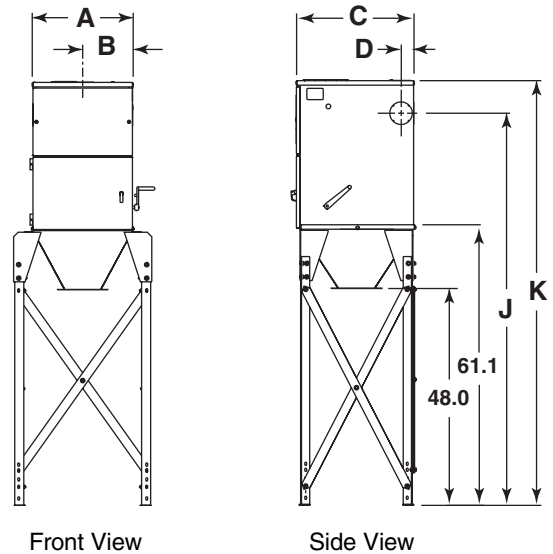
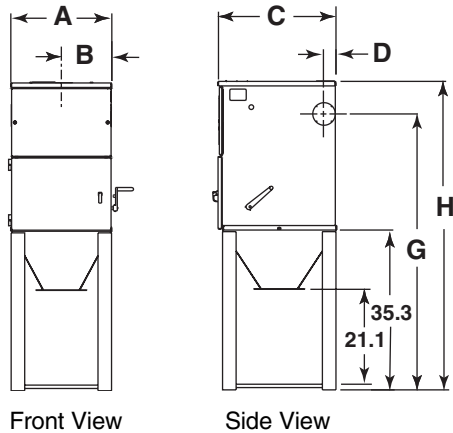

Model Series	Dimensions (in)									
	A	B	C	D	E	F	G	H	J	K
50	22.3	11.2	20.1	2.6	21.9	26.9	62.2	57.2	N/A	N/A
60	22.4	11.2	26.3	2.8	25.7	32.9	68.2	61.0	86.8	94.0
70	22.4	11.2	26.3	2.8	36.3	43.5	78.9	71.1	97.5	104.7
80	28.5	14.2	29.3	4.3	40.6	47.8	83.5	75.9	101.7	109.3

Model Series	Filter Area (ft ²)	No. of Bags	Dust Drawer Capacity (ft ³)	Hopper Capacity (ft ³)	Shipping Weight (lbs)		
					Cabinet Base	5-Gallon Pail	55-Gallon Drum
50	30	24	0.43	1.86	165	236	--
60	60	24	0.43	2.34	170	265	298
70	120	24	0.93	2.34	245	340	372
80	150	30	2.00	3.16	365	472	495

Cabinet Dust Collectors

Standard Features

- Heavy-gauge, fully-welded cabinet
- Galvanized shaker bar
- Factory installed cotton sateen filter packs
- Dynamically balanced steel fan wheel
- Inlet locations on top and all three sides
- Blue indoor industrial-grade texturized paint
- TEFC motor
- 115/230/60/1 or 208-230/460/60/3 voltages (availability based on collector size)
- 10-year warranty

Equipment Options

- Automatic shaker
- Brass shaker bar
- Aluminum fan wheel
- Explosion-proof motor
- 5-gallon pail pack
- 55-gallon drum pack
- Slide gate
- Hopper or dump hopper
- Inlet collar kit
- Exhaust deflector
- Chamber, attenuator, or stack silencer
- Suction-tube assembly
- Outrigger pack
- Explosion vent
- HEPA filter
- Motor starter
- Casters
- Magnehelic® gauge
- EZ Filter Pack
 - Polyester sateen
 - Woven polyester
 - Polypropylene
 - Stainless steel construction
 - Nonspark

* Availability based on collector size.

** Magnehelic® is a registered trademark of Dwyer Instruments, Inc.



Donaldson

Filtration Solutions

Donaldson Company, Inc.
Industrial Air Filtration
P.O. Box 1299
Minneapolis, MN 55440

Tel 800-365-1331(USA)
Tel 800-343-3639 (within Mexico)
dustmktg@mail.donaldson.com
www.donaldson.com

Significantly improve the performance of your collector with genuine Donaldson Torit replacement filters and parts.

Visit us at www.donaldsondynamic.com

Information in this document is subject to change without notice.

© 1990 Donaldson Co., Inc.
Printed in U.S.A. on recycled paper

Data Sheet CAB 50-80 (03/05)

